

ItemUnit-TE Advanced

The Traxeed ItemUnit-Tamper Evident is a modular system for online coding, serialization and verification of single items in the pharmaceutical packaging process.

The ItemUnit-Tamper Evident combines a precise product transport (four lane conveyors) with printing, vision control, tamper evident seal application, reject system and the batch controller. Configurable software features with integrated label designer and automatic vision configuration based on the label design make the system compliant with track and trace regulations worldwide.



FEATURES

Conveyor system

- Servo driven four lane conveyor belt
- Belt speed adjustable up to 70 m/min
- Up to 400 ppm
- Transfer height variable from 750 to 1000 mm
- One transport system for laser and ink jet print systems

Machine cover

- Plexiglass cover
- Lockable door safety switch

Coding system options

- Thermal inkjet printer Wolke m610 OEM
- Thermal inkjet printer Domino G320i OEM
- CO₂ laser printer Domino D620i (60W)
- CO₂ laser printer Videojet VJ 3330 (30W)

Tamper evident seal applicator

- Herma Tamper Evident Seal Applicator

Inspection system

- Traxeed vision system including camera station and LED lighting (b/w CCD-Matrix-Camera, 1296 x 996 pixel)
- Optional: Cognex vision system including smart camera and LED lighting (b/w CMOS-Camera, 1280 x 1024 pixel)
- Field of view: W = 60 mm, H = 40 mm
- Additional camera station to verify data in up to two different positions simultaneously

Reject station

- Pneumatic driven air blower
- Reject verification with light barrier
- Rejected products are collected in a reject bin
- Optional additional reject stations

Industrial PC

- B&R Industrial PC
- CPU Intel Core i7 Quad Core 2.3 GHz
- RAM 4 GB DDR3
- SSD 60 GB
- 18,5" Widescreen TFT Touch Screen

FEATURES

Additional accessories

- Optional speed controlled infeed and outfeed conveyor belts
- Handheld code scanner
- Reject bin suitable for heavy cartons (e.g. carton with bottle)
- Pusher for ejecting heavy cartons

Installation requirements

- Voltage: 230 V, 50 Hz / 110 V, 60 Hz (L, N, PE)
- Power: approx. 1.0 kW
(can vary with the machine options)
- Compressed air: 6 bar clean dry air / consumption at continuous operation approx. 90 Nm³/h

Operating Conditions

- Temperature: 10°C – 40°C
- Humidity: 0% – 80% RH (non-condensing)

Please note

- High humidity can have negative effects on print quality (grading, blur of print)
- For thermal ink jet print systems: High humidity might cause longer ink dry time which has an impact on the machine vision inspection and could lead to higher false rejects rate
- It might be necessary to reduce the print resolution or the transport speed of the system in order to increase the ink dry time
- For thermal ink jet print systems: High humidity might lead to a shorter cleaning interval for the nozzle of the thermal ink jet cartridges

SPECIFICATIONS

Product dimensions

	min.	max.
Width (W)	15 mm	180 mm
Height (H)	15 mm	125 mm
Length (L)	70 mm*	260 mm
Weight	30 g	300 g

* with 20 mm tamper evident label, and 82 mm with 32 mm label.
Other product dimensions have to be evaluated by Traxeed.

Sample print layout

- A Barcode size
- B Code field length
- D Line space
- L Text length
- H Text height
- Q Quiet zone

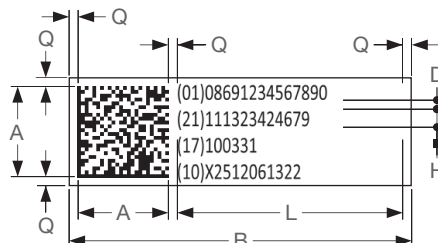

Conveyor system

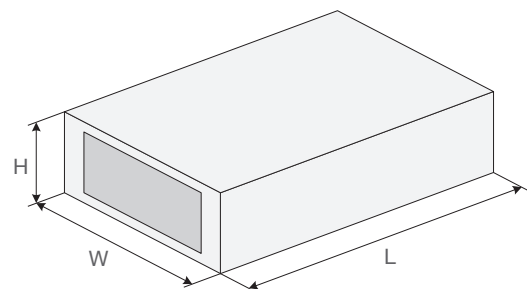
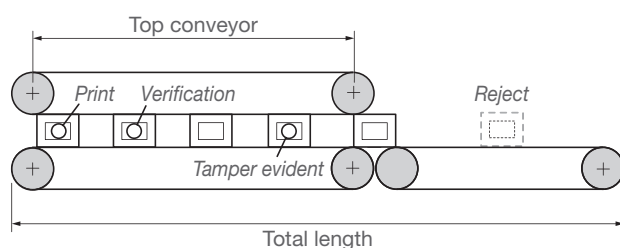

Print positions

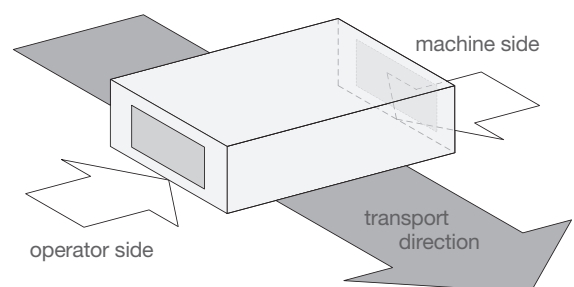

Tamper evident label position

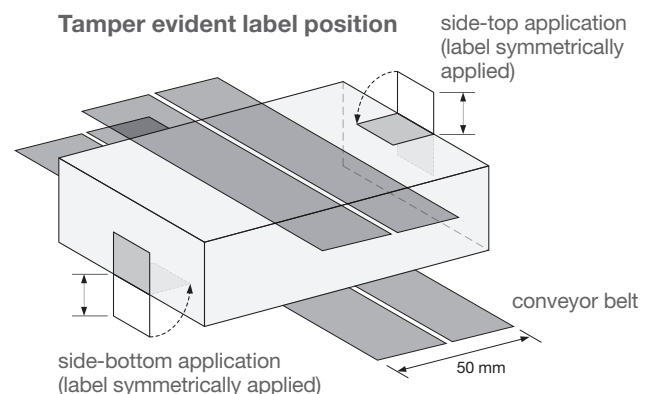

CODING SYSTEMS

Thermal inkjet printer Wolke m610 oem / Domino G320i OEM

- Resolution 300 dpi
- Coding speed up to 60 m/min
- Print height 12.7 mm per print head
- Up to 4 print heads to print in up to two locations simultaneously or to increase print height to 25.4 mm (max. 2 print heads on one side)

CO₂ laser printer Domino D620i

- 60 watt air cooled
- Coding speed up to 50 m/min (depends on print content; typical 35 m/min)

CO₂ laser printer Videojet VJ3340

- 30 watt air cooled
- Coding speed up to 40 m/min (depends on print content; typical 35 m/min)

TAMPER EVIDENT SEAL APPLICATOR

Herma Tamper Evident Seal Applicator

- Position Accuracy: ± 2 mm
- Application evaluation by gloss sensor
- Up to 300 ppm

Tamper evident label Information

- Width: min. 15 mm, max. 40 mm
- Length: min. 15 mm, max. 40 mm
- Label roll diameter: max. 400 mm
- Label roll core diameter: 76.2 mm
- Label gap: min. 3 mm
- Recommended label material: Polypropylene, PP-Foil (51 μ m thickness)
- Recommended Carrier Material: Polyester, PET-Foil (30 μ m thickness)
- Please note that all customer labels have to be evaluated by Traxeed before use

DIMENSIONS

Space requirements:

- Maximum frame length: 1510 mm (depending on system configuration)
- Total depth: 1926 mm (incl. electrical cabinet)
- Total height: max. 2600 mm

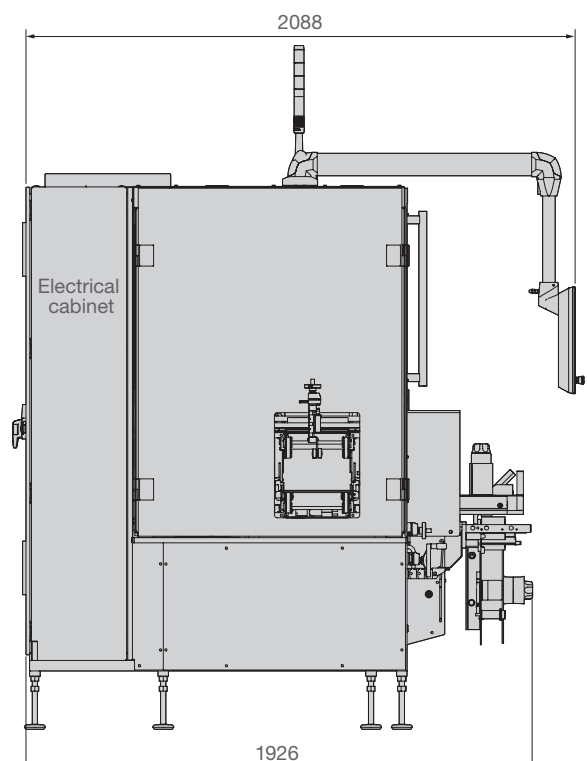
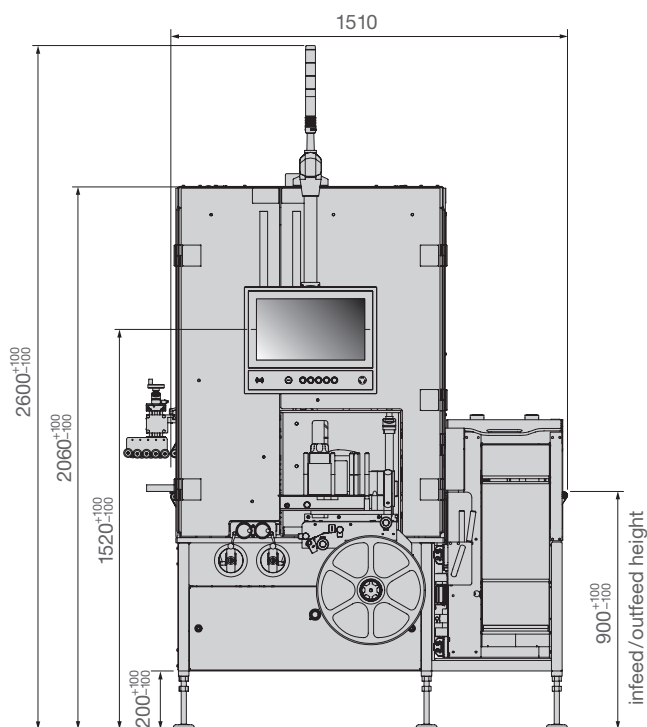

TRAXEED LIFE CYCLE SERVICE



Traxeed Service Desk

The Service Desk is staffed by qualified experts. They can provide 24/7 service 360 days a year. The Service Desk combines maximum competence with short response and solution times.



Traxeed Academy

Our customized training and support programs impart theoretical and practical knowledge to enhance the productivity of your employees.



Traxeed Field Service

Our technicians have the expertise and understanding that comes from time, training, dedication to their craft and determination to provide superior service to every customer.



Traxeed Original Spare Parts

We stock an extensive inventory of original spare parts at our worldwide locations to ensure speedy delivery. Machine-specific spare parts packages are also offered to give you in-house stock for immediate installation.



Traxeed Retrofit/Upgrades

Retrofit: For more flexibility and functionality, take advantage of the modularity and expandability of your machines and profit from consistently modern equipment. Upgrades: Improve your installed equipment and software with upgrades.



Traxeed Process Optimization/OEE

Consulting and technical support to increase equipment performance, availability and reliability.